

Rimage® Producer™ V Non-Embedded Setup and Installation Guide

Before you begin:

This document describes how to set up your Rimage Producer V non-embedded product to run with Rimage Software Suite version 8.6 and higher.

The instructions in this document are intended for people who are familiar with hardware setup, software installation, and Windows® operating systems. If you do not understand the procedures in this document, ask your computer technician for help.

Documents referenced in this procedure are found on the Rimage Producer V User Guide disc included with your system and are also available online at www.rimage.com/support.

Important!

- Read all setup instructions thoroughly before you begin.
- Save all packing boxes and packing materials for your Rimage system.

Notes:

- The Producer V non-embedded autoloader is available with either the Everest Encore or Prism III printer and requires an external PC to be used as the control center. The external PC does not ship with the Producer V non-embedded system. Refer to the Rimage Producer V Specification document at www.rimage.com/support for minimum PC requirements.
- Your product may not look exactly like the product pictured.
- You must have administrative privileges to install the Rimage Software Suite.
- The term “autoloader” is used throughout this document to refer to the Producer V products. The term “printer” refers to the Everest Encore or Prism III printer. The term “system” refers to the combination of the Producer V autoloader and printer.
- This product is also designed for an IT power distribution system with phase-to-phase voltage 120/230V.
- Unless otherwise indicated, all Windows navigation statements are Windows 10 paths. Other operating systems’ navigation paths may differ slightly.

2 Prepare the autoloader

Important! The system is heavy. Use assistance when lifting the system.

- Remove the **Software Agreement label** from the front door.

Important! Read the label before you remove it. By removing the label, you are agreeing to the terms and conditions set forth in the agreement.

- Open the **front door**.

Tip: If the system is locked, the keys are located in the accessory kit that shipped with your system.

- Remove the **protective foam** from the inside of the door.
- Cut the **plastic tie wrap** from the lift arm.

Caution! Do not cut the belt or the cable!

- Remove the **tape** from the disc diverter.
- Remove the **shipping foam** inserted above the carousel.
- See instructions near Gripper to disengage the Gripper Restraint.
- Close the **door**.

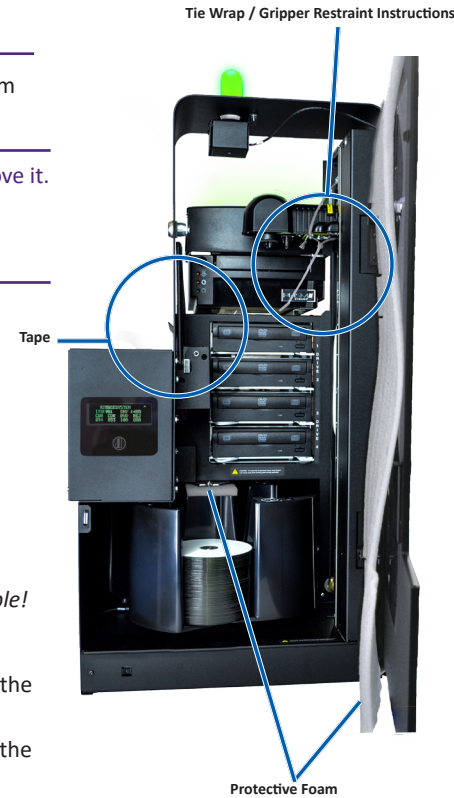

3 Set up your printer

Prism III™

- Unpack the **Prism III printer**. Refer to the label on the Prism printer box.

Note: The Prism print ribbon is preinstalled.

- Place the **printer** on the Rimage Producer V so that the plastic printer feet slide into the slots on the printer plate.

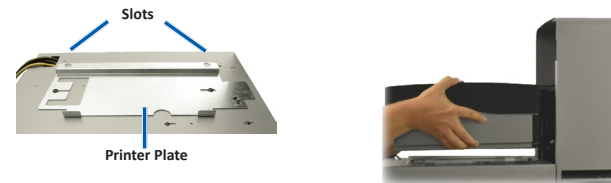

- Connect the **cables**.
 - Connect the **USB cable** from the Producer V to the printer.
 - Connect the **printer cable** from the Producer V to the printer.
 - Connect the **power cord** from the Producer V to the printer.
- Press the **Prism printer power switch** to the On position.

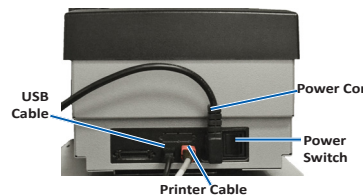

3 Set up your printer (continued)

Everest Encore™

- Unpack the **Everest Encore printer**. Refer to the label on the Everest printer box.

- Follow the instructions on the **instruction card** on the rear of the printer.
 - Set the **AC voltage switch**.
 - Move the **shipping screw** to the storage position.

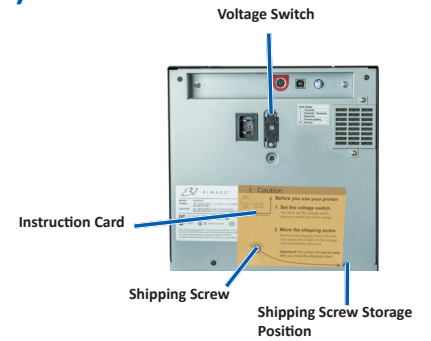

- Open the **Everest Encore printer**.
 - Press the two **side cover latches**.
 - Lower the **side cover**.

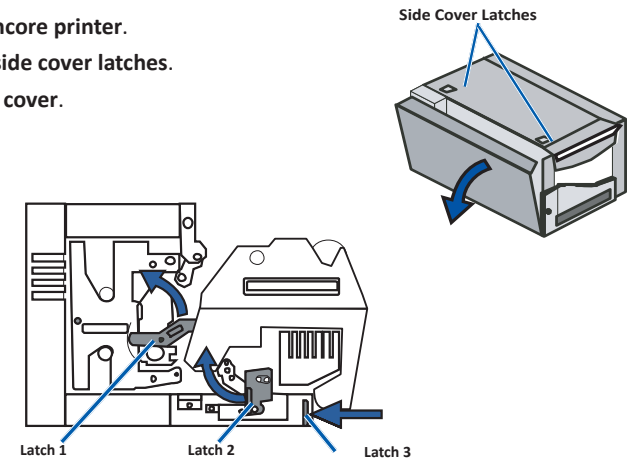

- Open **latches 1, 2, and 3** as indicated by the arrows.

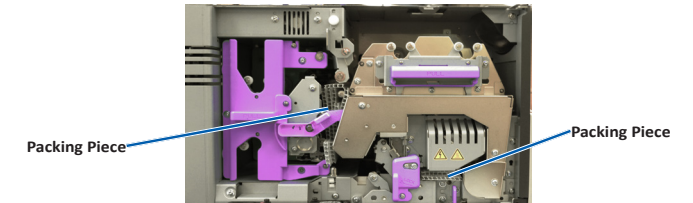

- Remove the **plastic packing pieces** (Qty. 2) from inside the printer.

- Install the **print ribbon**.
 - Grasp the handle and pull to remove the **print ribbon carrier** all the way out of the printer.

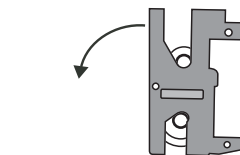
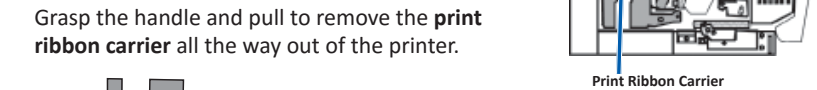

- Lay the **print ribbon carrier** on its back on a clean, flat surface.

- Wrap the **print ribbon** around the guide rollers, as shown.

- Snap the **supply roll** and **take-up roll** into the print ribbon carrier.

- Tighten the **print ribbon** by turning the take-up roll clockwise.

- Insert the **print ribbon carrier** into the printer.

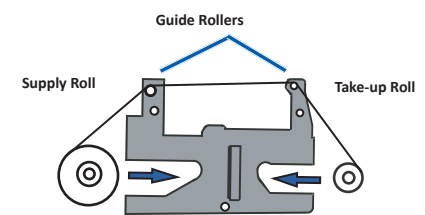

Items needed:

- A **network cable** is needed if you plan on submitting jobs or accessing files from a networked PC.
- An external PC.
- Scissors or side cutters
- Phillips screwdriver

1 Verify the contents of the Accessory Kit

The Accessory Kit contains:

- Rimage Producer V Non-Embedded Setup and Installation Guide (this document)
- Rimage Product Warranty/Guarantee
- A/C cord
- USB cable
- Rimage Producer V User Guide disc
- Disc holder with Rimage Software Suite disc
- System door keys

3 Set up your printer (continued)

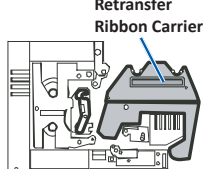
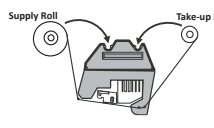
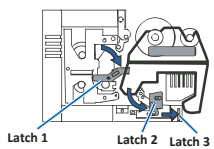
- g. Install the new transfer ribbon
 - i. Grasp the handle to slide the **retransfer ribbon carrier** out of the printer.
 - ii. Slide the **retransfer ribbon** under the retransfer ribbon carrier.

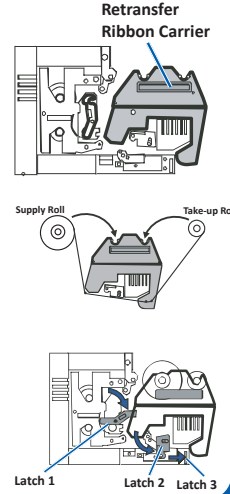
 - iii. Snap the **supply roll** and **take-up roll** onto the carrier.

 - iv. Tighten the **retransfer ribbon** by turning the takeup roller counterclockwise.
 - v. Slide the **retransfer ribbon carrier** into the printer.

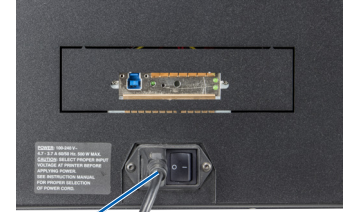
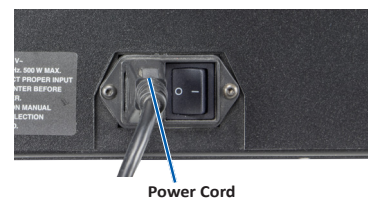
 - vi. Close **latches 1, 2, and 3**, as indicated by the arrows.
- h. Close the printer **side cover**.



4 Connect the power cable and power on the system

- a. Make sure the external PC is powered on.
- b. Connect the **power cord** to the autoloader.

- c. Connect the power cord from the back of the autoloader to a power outlet.

Important!

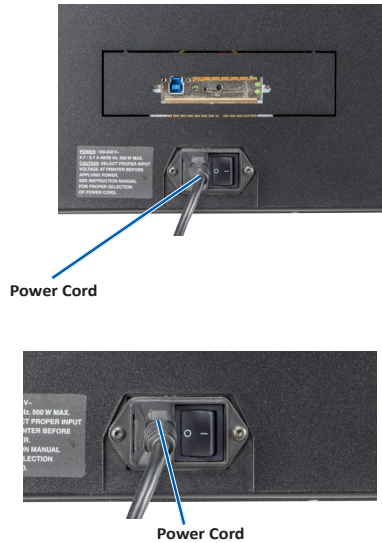
 - Do not power on the Producer V until you are instructed to do so.
 - Do not connect the USB cable at this time.
 - The outlet must be an earth-grounded outlet.
- d. Press the power switch at the back of the autoloader.
The autoloader powers on.



5 Load discs in the system

The default bin configuration is:

- Load CDs in Bin 1.
- Load DVDs in Bin 2.
- Load DVD-DL in Bin 3.
- Bin 4 is output/reject.
- External Bin is not used.

Refer to the *Rimage Producer V User Guide* for information on changing bin configuration.

Note: If you have a Blu-ray Disc™ system, refer to your user guide for bin configuration information.

6 Install the software and plug in the USB cable

Important! Do not plug in the USB cable until instructed to do so.

Note: You must have administrative privileges to install the software on the external PC.

- a. Place the **Rimage Software Suite** in the disc drive of the external PC.

Tip: If the software installation does not start automatically, browse to the `setup.exe` file on the software disc.

- b. Follow the on screen prompts to complete the software installation.
- c. When prompted, connect the **USB cable**.
 - i. Connect the **USB cable** to the back of the autoloader.
 - ii. Connect the **USB cable** to the external control center (PC).

Tip: For best performance, Rimage recommends using USB 3

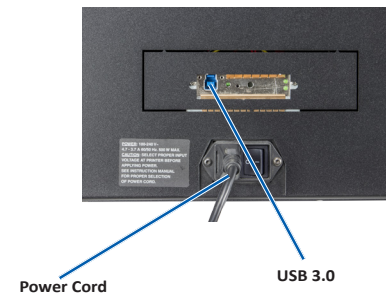

Note: You can plug the USB 3 cable into a USB 2 port.

- d. Continue to follow the on screen prompts to complete installation. Once installation is complete, you may be prompted to reboot your system.

Note: After the software starts, the system begins the initialization process. Initialization may take up to 5 minutes. During the initialization process the lift arm moves to each recorder and the printer. When the lift arm assembly stops moving, initialization is complete and your system is ready to process jobs.

7 Test and verify

Use QuickDisc™ to run a 3-disc test job to verify that the system is operating correctly.

Note: You can now use Rimage WebRSM™ to adjust the system settings.

8 Learn more

- These documents are available on the **Rimage Producer V User Guide disc** that shipped with your autoloader:
 - *Rimage Producer V User Guide*
 - *Diagnostic Test Instructions*

Access these documents by placing the **User Guide disc** in the disc drive of a PC.

Note: If the User Guide menu does not display automatically, browse to the `Home.htm` file on the software disc.

- For information about operating and maintaining the Producer V, refer to the *Rimage Producer V User Guide*.
- For additional support and product information, go to www.rimage.com/support.